

Product Information Sheet

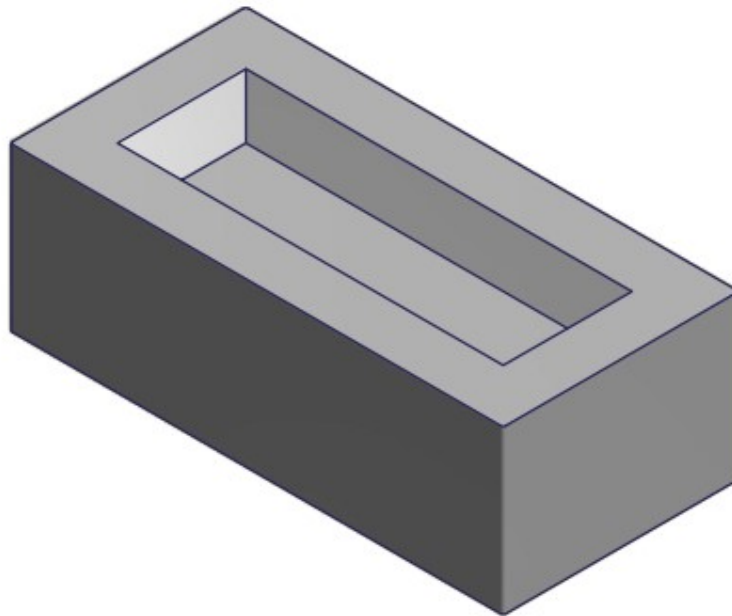

Description:	Common brick load bearing standard
Product code:	M12715WHNAT00ST
Dimensions:	76 x 110 x 230 mm (H x W x L) Category DW4 as per AS 4455.1, determined in accordance with AS/NZS 4456.3.
Strength:	Characteristic Compressive Strength ≥ 10 MPa
Fire Resistance:	120 /120/120 (Srf ≤ 21.14)
Durability:	Exposure Grade (determined by AS/NZS 4456.10 - Resistance to Salt Attack)
Weight:	3.4 Kg $\pm 10\%$
No. Per pallet:	500 Units
No. Per m²:	48.5 Units



Manufactured to AS/NZS 4455.1 & 4455.3:2008

Fire Resistance Levels as per Exova Warringtonfire Assessment Report #28339-00.

The information above is for general description purposes only.

30/04/2019 - subject to change without notice.